

# A593



## ZAMAK ALLOY INDEXED CLAMPING LEVER WITH MALE THREADED INSERT

**Material:**  
Die cast Zamak lever body  
(zinc, aluminium, copper alloy).

**Surface:**  
Smooth. Epoxy-powder painting finish.

**Lever body colours:**  
Shiny Black (RAL 9005 cod. 01)  
Matt Black (RAL 9005 cod. 20)  
Orange (RAL 2004 cod. 02)  
Grey (RAL 7031 cod. 80)  
Silver (RAL 9006 cod. 83)  
Red (RAL 3000 cod. 16)  
Blue (RAL 5015 cod. 07)  
Natural Zamak (cod. GRE)

**Main insert:**  
Black-oxide steel insert, with male threaded stud.  
(Thread tolerance 6g).

**Fixing screw:**  
Black-oxide treated steel screw with hexagon  
socket head.

**Spring:**  
Stainless steel spring (AISI 302).

### SPECIAL REQUESTS:

- It's possible to supply the inserts with different lengths, on request and for 300 pieces minimum.

Attention: for insert lengths over LM, we'll use glued zinc plated steel male thread.

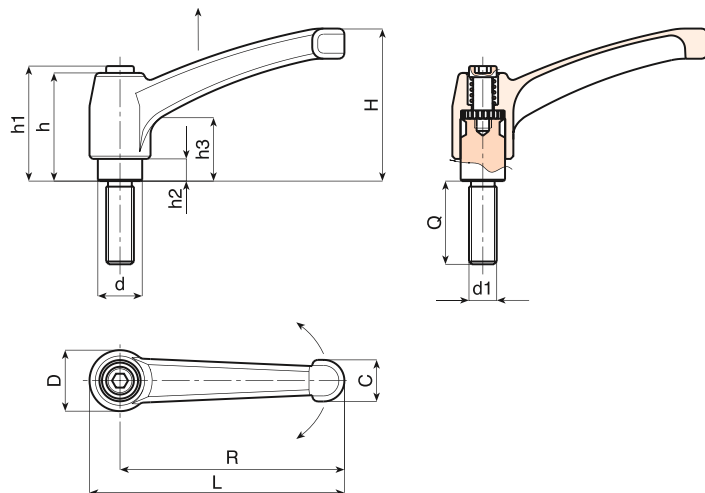

Art.	L	R	H	D	d	c	h	h1	h2	h3	LM	d1 6g	Q	⚖ g
A593043.ZM04X....	50	43	30	14	10	9	26	30	5	14	50	M04	16-20-25-30	30-30-31-31
A593043.ZM05X....	50	43	30	14	10	9	26	30	5	14	50	M05	16-20-30-40	31-32-34-35
A593043.ZM06X....	50	43	30	14	10	9	26	30	5	14	60	M06	16-20-25-30-40-50	31-32-33-34-35-36
A593043.ZM08X....	50	43	30	14	10	9	26	30	5	14	60	M08	16-25-30-40-50	35-38-40-43-46
A593065.ZM06X....	75	65	45	19	14	13	32	34	7	14	60	M06	20-30-40-50	82-84-86-88
A593065.ZM08X....	75	65	45	19	14	13	32	34	7	14	60	M08	16-20-25-30-35 40-45-50	82-83-84-86-88 89-90-92
A593065.ZM10X....	75	65	45	19	14	13	32	34	7	14	60	M10	20-25-30 40-50	89-91-94 99-104
A593080.ZM08X....	91	80	57	22	16	16	40	42	8	16	60	M08	20-25-30 35-40-50	142-144-145 147-148-151
A593080.ZM10X....	91	80	57	22	16	16	40	42	8	16	60	M10	20-25-30-35 40-50-60	146-148-151-153- 156-161-166
A593080.ZM12X....	91	80	57	22	16	16	40	42	8	16	70	M12	20-30-40-50-60	150-157-164-171-178
A593094.ZM12X....	107	94	65	26	20	17,5	47	50	10,5	19	70	M12	20-30-40-50	229-236-243-250
A593094.ZM14X....	107	94	65	26	20	17,5	47	50	10,5	19	70	M14	30-35-40-50-60	240-245-250-260-270
A593094.ZM16X....	107	94	65	26	20	17,5	47	50	10,5	19	80	M16	30-40-50	254-266-278
A593108.ZM12X....	123	108	75	30	23	20	54	56	12	23	80	M12	25-50	330-347
A593108.ZM14X....	123	108	75	30	23	20	54	56	12	23	80	M14	30-40-60	340-360-380
A593108.ZM16X....	123	108	75	30	23	20	54	56	12	23	80	M16	30-40-50-60	342-356-370-384
A593108.ZM18X....	123	108	75	30	23	20	54	56	12	23	80	M18	A.R.	-

LM = Maximum turning length.

Enter the colour choice and stud length in the four .... of the article code. Example: Red lever R80 M10x30 - A592080.ZM10X3016

Presumable presence in the stock in %   
 90% ● 40% ● 5% ●

A